

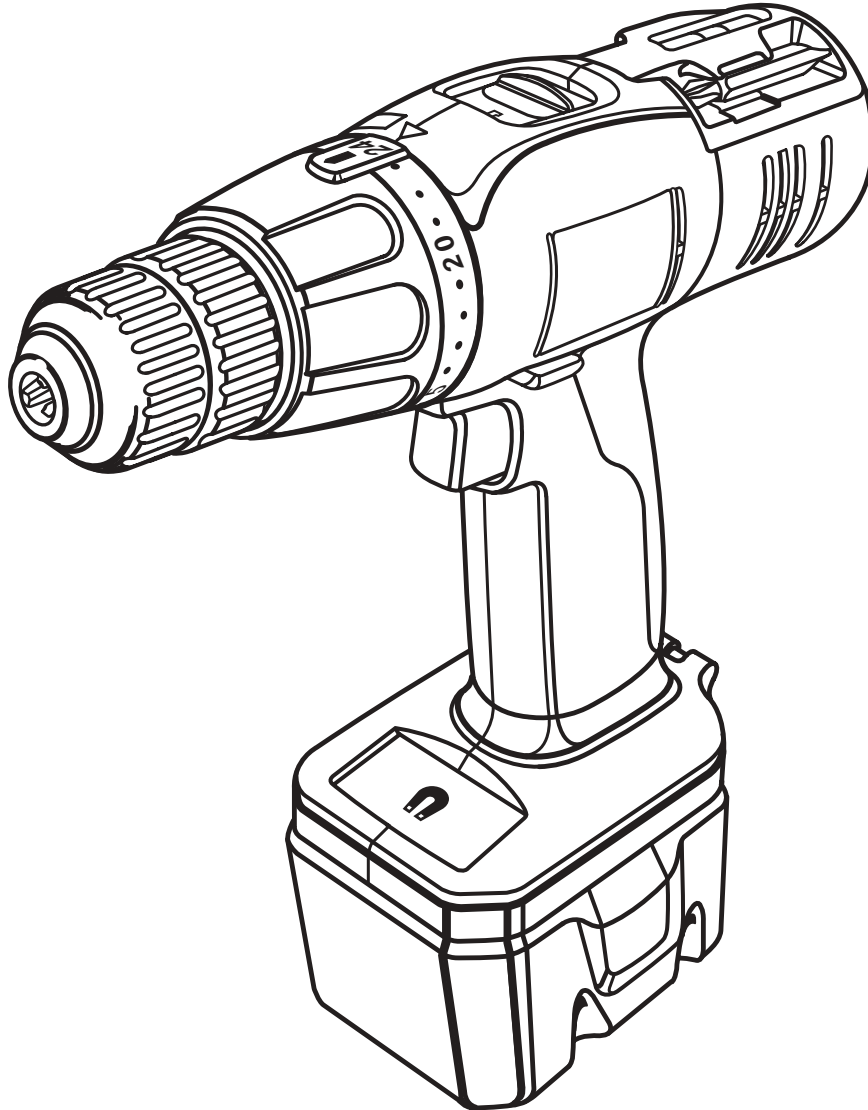

OPERATOR'S MANUAL CORDLESS DRILL-DRIVER MODEL NOS. SA1202 / SA14402 / SA1802



This new drill has been engineered and manufactured to our Ryobi's high standard for dependability, ease of operation, and operator safety. When properly cared for, the drill will give you years of rugged, trouble-free performance.

⚠ WARNING:

To reduce the risk of injury, the user must read and understand the operator's manual before using this product.

Thank you for buying a Ryobi product.

SAVE THIS MANUAL FOR FUTURE REFERENCE

TABLE OF CONTENTS

■ Introduction	2
■ General Safety Rules	3-4
■ Specific Safety Rules	4
■ Important Safety Instructions for Charger	5
■ Symbols	6
■ Specifications	7
■ Unpacking	7
■ Applications	7
■ Features	8-9
■ Adjustments	10-12
■ Operation	13-16
■ Maintenance	17-18
■ Parts Ordering / Service	20

INTRODUCTION

The Cordless Drill-Driver has many features for making the use of this product more pleasant and enjoyable. Safety, performance, and dependability have been given top priority in the design of this product making it easy to maintain and operate.

WARNING:

Do not attempt to use this product until you thoroughly read and completely understand the operator's manual. Pay close attention to the safety rules, including Dangers, Warnings, and Cautions. If you use your product properly and only as intended, you will enjoy years of safe, reliable service.



Look for this symbol to point out important safety precautions. It means attention!!! Your safety is involved.

WARNING:



The operation of any tool can result in foreign objects being thrown into your eyes, which can result in severe eye damage. Before beginning operation, always wear safety goggles or safety glasses with side shields and a full face shield when needed. We recommend Wide Vision Safety Mask for use over eye-glasses or standard safety glasses with side shields. Always wear eye protection which is marked to comply with ANSI Z87.1.

GENERAL SAFETY RULES

WARNING:

Read and understand all instructions. Failure to follow all instructions listed below, may result in electric shock, fire and/or serious personal injury.

SAVE THESE INSTRUCTIONS

WORK AREA

- **Keep your work area clean and well lit.** Cluttered benches and dark areas invite accidents.
- **Do not operate power tools in explosive atmospheres, such as in the presence of flammable liquids, gases, or dust.** Power tools create sparks which may ignite the dust or fumes.
- **Keep bystanders, children, and visitors away while operating a power tool.** Distractions can cause you to lose control.

ELECTRICAL SAFETY

- **A battery operated tool with integral batteries or a separate battery pack must be recharged only with the specified charger for the battery.** A charger that may be suitable for one type of battery may create a risk of fire when used with another battery.
- **Use battery operated tool only with specifically designated battery pack.** Use of any other batteries may create a risk of fire.
- **Use battery only with charger listed.**

MODEL	BATTERY PACK	CHARGER
SA1202	130147008	140120005
SA14402	130224010/1314702	1412001
SA1802	130224007/1323303 1322401/130256001	1423701

- **Do not abuse the cord. Never use the cord to carry the charger. Keep cord away from heat, oil, sharp edges, or moving parts. Replace damaged cords immediately.** Damaged cords may create a fire.

PERSONAL SAFETY

- **Stay alert, watch what you are doing and use common sense when operating a power tool. Do not use tool while tired or under the influence of drugs, alcohol, or medication.** A moment of inattention while operating power tools may result in serious personal injury.
- **Dress properly. Do not wear loose clothing or jewelry. Contain long hair. Keep your hair, clothing, and gloves away from moving parts.** Loose clothes, jewelry, or long hair can be caught in moving parts.
- **Avoid accidental starting. Be sure switch is in the locked or off position before inserting battery pack.** Carrying tools with your finger on the switch or inserting the battery pack into a tool with the switch on invites accidents.

- **Remove adjusting keys or wrenches before turning the tool on.** A wrench or a key that is left attached to a rotating part of the tool may result in personal injury.
- **Do not overreach. Keep proper footing and balance at all times.** Proper footing and balance enable better control of the tool in unexpected situations.
- **Use safety equipment. Always wear eye protection.** Dust mask, non-skid safety shoes, hard hat, or hearing protection must be used for appropriate conditions.

TOOL USE AND CARE

- **Use clamps or other practical way to secure and support the workpiece to a stable platform.** Holding the work by hand or against your body is unstable and may lead to loss of control.
- **Do not force tool. Use the correct tool for your application.** The correct tool will do the job better and safer at the rate for which it is designed.
- **Do not use tool if switch does not turn it on or off.** A tool that cannot be controlled with the switch is dangerous and must be repaired.
- **Disconnect battery pack from tool or place the switch in the locked or off position before making any adjustments, changing accessories, or storing the tool.** Such preventive safety measures reduce the risk of starting the tool accidentally.
- **Store idle tools out of reach of children and other untrained persons.** Tools are dangerous in the hands of untrained users.
- **When battery pack is not in use, keep it away from other metal objects like: paper clips, coins, keys, nails, screws, or other small metal objects that can make a connection from one terminal to another.** Shorting the battery terminals together may cause sparks, burns, or a fire.
- **Maintain tools with care. Keep cutting tools sharp and clean.** Properly maintained tools with sharp cutting edges are less likely to bind and are easier to control.
- **Check for misalignment or binding of moving parts, breakage of parts, and any other condition that may affect the tool's operation. If damaged, have the tool serviced before using.** Many accidents are caused by poorly maintained tools.
- **Use only accessories that are recommended by the manufacturer for your model.** Accessories that may be suitable for one tool may create a risk of injury when used on another tool.
- **Keep the tool and its handle dry, clean and free from oil and grease.** Always use a clean cloth when cleaning. Never use brake fluids, gasoline, petroleum-based products, or any strong solvents to clean your tool. Following this rule will reduce the risk of loss of control and deterioration of the enclosure plastic.

GENERAL SAFETY RULES

SERVICE

- **Tool service must be performed only by qualified repair personnel.** Service or maintenance performed by unqualified personnel may result in a risk of injury.
- **When servicing a tool, use only identical replacement parts. Follow instructions in the Maintenance section of this manual.** Use of unauthorized parts or failure to follow Maintenance Instructions may create a risk of shock or injury.

SPECIFIC SAFETY RULES

- **Hold tool by insulated gripping surfaces when performing an operation where the cutting tool may contact hidden wiring.** Contact with a "live" wire will also make exposed metal parts of the tool "live" and shock the operator.

ADDITIONAL RULES FOR SAFE OPERATION

- **Know your power tool. Read operator's manual carefully. Learn its applications and limitations, as well as the specific potential hazards related to this tool.** Following this rule will reduce the risk of electric shock, fire, or serious injury.
- **Always wear safety glasses with side shields.** Everyday glasses have only impact resistant lenses. They are NOT safety glasses. Following this rule will reduce the risk of eye injury.

IMPORTANT RULES FOR BATTERY TOOLS

- **Battery tools do not have to be plugged into an electrical outlet; therefore, they are always in operating condition. Be aware of possible hazards when not using your battery tool or when changing accessories.** Following this rule will reduce the risk of electric shock, fire, or serious personal injury.
- **Do not place battery tools or their batteries near fire or heat.** This will reduce the risk of explosion and possibly injury.
- **WARNING:** Batteries vent hydrogen gas and can explode in the presence of a source of ignition, such as a pilot light. To reduce the risk of serious personal injury, never use any cordless product in the presence of open flame. An exploded battery can propel debris and chemicals. If exposed, flush with water immediately.
- **Do not charge battery tool in a damp or wet location.** Following this rule will reduce the risk of electric shock.
- **For best results, your battery tool should be charged in a location where the temperature is more than 50°F but less than 100°F. Do not store outside or in vehicles.**
- **Under extreme usage or temperature conditions, battery leakage may occur. If liquid comes in contact with your skin, wash immediately with soap and water, then neutralize with lemon juice or vinegar. If liquid gets into your eyes, flush them with clean water for at least 10 minutes, then seek immediate medical attention.** Following this rule will reduce the risk of serious personal injury.

IMPORTANT SAFETY INSTRUCTIONS FOR CHARGER

WARNING:

Read and understand all instructions. Failure to follow all instructions listed below, may result in electric shock, fire and/or serious personal injury.

- **Never use a battery that has been dropped or received a sharp blow.** A damaged battery is subject to explosion. Properly dispose of a dropped battery immediately. Failure to heed this warning can result in serious personal injury.
- **Save these instructions.** This manual contains important safety and operating instructions for charger.
- **Before using battery charger, read all instructions and cautionary markings in this manual, on battery charger, and product using battery charger.** Following this rule will reduce the risk of electric shock, fire, or serious personal injury.
- **CAUTION: To reduce risk of injury, charge only nickel-cadmium type rechargeable batteries. Other types of batteries may burst causing personal injury and damage.** Following this rule will reduce the risk of electric shock, fire, or serious personal injury.
- **Do not expose charger to wet or damp conditions.** Following this rule will reduce the risk of electric shock, fire, or serious personal injury.
- **Use of an attachment not recommended or sold by the battery charger manufacturer may result in a risk of fire, electric shock, or injury to persons.** Following this rule will reduce the risk of electric shock, fire, or serious personal injury.
- **To reduce risk of damage to charger body and cord, pull by charger plug rather than cord when disconnecting charger.** Following this rule will reduce the risk of electric shock, fire, or serious personal injury.
- **Make sure cord is located so that it will not be stepped on, tripped over, or otherwise subjected to damage or stress.** Following this rule will reduce the risk of serious personal injury.
- **Do not abuse cord. Never carry tool by cord or yank it to disconnect from receptacle. Keep cord from heat, oil and sharp edges.** Following this rule will reduce the risk of electric shock or fire.
- **An extension cord should not be used unless absolutely necessary.** Use of improper extension cord could result in a risk of fire and electric shock. If extension cord must be used, make sure:
 - a. That pins on plug of extension cord are the same number, size and shape as those of plug on charger.
 - b. That extension cord is properly wired and in good electrical condition; and

- c. That wire size is large enough for AC ampere rating of charger as specified below:

Cord Length (Feet)	25'	50'	100'
Cord Size (AWG)	16	16	16

Note: AWG = American Wire Gauge

- **Do not operate charger with a damaged cord or plug. If damaged, have replaced immediately by a qualified serviceman.** Following this rule will reduce the risk of electric shock, fire, or serious personal injury.
- **Do not operate charger if it has received a sharp blow, been dropped, or otherwise damaged in any way; take it to a qualified serviceman.** Following this rule will reduce the risk of electric shock, fire, or serious personal injury.
- **Do not disassemble charger; take it to a qualified serviceman when service or repair is required. Incorrect reassembly may result in a risk of electric shock or fire.** Following this rule will reduce the risk of electric shock, fire, or serious personal injury.
- **To reduce the risk of electric shock, unplug charger from outlet before attempting any maintenance or cleaning. Turning off controls will not reduce this risk.** Following this rule will reduce the risk of electric shock, fire, or serious personal injury.
- **Disconnect charger from power supply when not in use.** Following this rule will reduce the risk of electric shock, fire, or serious personal injury.
- **Save these instructions. Refer to them frequently and use them to instruct others who may use this tool. If you loan someone this tool, loan them these instructions also.** Following this rule will reduce the risk of electric shock, fire, or serious personal injury.

WARNING:

Some dust created by power sanding, sawing, grinding, drilling, and other construction activities contains chemicals known to cause cancer, birth defects or other reproductive harm. Some examples of these chemicals are:



- lead from lead-based paints,
- crystalline silica from bricks and cement and other masonry products, and
- arsenic and chromium from chemically-treated lumber.

Your risk from these exposures varies, depending on how often you do this type of work. To reduce your exposure to these chemicals: work in a well ventilated area, and work with approved safety equipment, such as those dust masks that are specially designed to filter out microscopic particles.



SAVE THESE INSTRUCTIONS

SYMBOLS

Important: Some of the following symbols may be used on your tool. Please study them and learn their meaning. Proper interpretation of these symbols will allow you to operate the tool better and safer.

SYMBOL	NAME	DESIGNATION/EXPLANATION
V	Volts	Voltage
A	Amperes	Current
Hz	Hertz	Frequency (cycles per second)
min	Minutes	Time
~	Alternating Current	Type or a characteristic of current
≡	Direct Current	Type or a characteristic of current
n_0	No Load Speed	Rotational speed, at no load
.../min	Revolutions or Reciprocation Per Minute	Revolutions, strokes, surface speed, orbits etc. per minute
	Safety Alert Symbol	Indicates danger, warning or caution. It means attention!!! Your safety is involved.
	Wear Eye Protection	Always wear safety goggles or safety glasses with side shields when operating this product.
	Wet Conditions Alert	Do not expose to rain or use in damp locations.

The purpose of safety symbols is to attract your attention to possible dangers. The safety symbols, and the explanations with them, deserve your careful attention and understanding. The safety warnings do not by themselves eliminate any danger. The instructions or warnings they give are not substitutes for proper accident prevention measures.

Symbol	Meaning
	DANGER: Indicates an imminently hazardous situation which, if not avoided, will result in death or serious injury.
	WARNING: Indicates a potentially hazardous situation which, if not avoided, could result in death or serious injury.
	CAUTION: Indicates a potentially hazardous situation which, if not avoided, may result in minor or moderate injury. It may also be used to alert against unsafe practices that may cause property damage.
NOTE:	Advises you of information or instructions vital to the operation or maintenance of the equipment.

SAVE THESE INSTRUCTIONS

SPECIFICATIONS

DRILL-DRIVER	SA1202	SA14402	SA1802
Chuck	3/8 in. (10 mm) Keylessw	3/8 in. (10 mm) Keyless	1/2 in. (13 mm) Keyless
Motor	DC Motor 12 Volt	DC Motor 14.4 Volt	DC Motor 18 Volt
Gear Train	Two Speed	Two Speed	Two Speed
Switch	Variable Speed	Variable Speed	Variable Speed
No Load Speed	0-300 RPM (Low) 0-1000 RPM (High)	0-400 RPM (Low) 0-1400 RPM (High)	0-350 RPM (Low) 0-1300 RPM (High)
Clutch	24 Positions	24 Positions	24 Positions
Charger Input	120 V, 60 Hz, AC only	120 V, 60 Hz, AC only	120 V, 60 Hz, AC only
Charge Rate	1 Hour	1 Hour	1 Hour
Torque	Maximum 220 in.lbs.	Maximum 270 in.lbs.	Maximum 400 in.lbs.

UNPACKING

INSTRUCTIONS

When unpacking the tool:

- Carefully remove the tool and accessories from the box.
- Make sure that all items listed in the packing list are included.
- Inspect the tool carefully to make sure no breakage or damage occurred during shipping.
- Do not discard the packing material until you have carefully inspected and satisfactorily operated the tool.
- If any parts are damaged or missing, please call 1-800-525-2579 for assistance.

Cordless Drill

Charger

Battery Pack (2)

Operator's Manual

Case

WARNING:

If any parts are missing do not operate the tool until the missing parts are replaced. Failure to do so could result in possible serious personal injury.

APPLICATIONS

You may use the two speed drill for the purposes listed below:

- Drilling in wood
- Drilling in ceramics, plastics, fiberglass, and laminates
- Drilling in both hard and soft metals
- Using driving accessories, such as driving screws with screwdriver bits
- Mixing paints

FEATURES

KNOW YOUR DRILL-DRIVER

See Figure 1.

Before using this tool, familiarize yourself with all operating features and safety requirements. However, do not let familiarity with the tool make you careless.

This new drill-driver is equipped with the following features.

KEYLESS CHUCK

The drill-driver has a keyless chuck that allows you to hand tighten or release drill bit in the chuck jaws.

SWITCH

The drill-driver has a conveniently located variable speed switch.

SWITCH LOCK

The switch trigger can be locked in the **OFF** position. This feature helps reduce the possibility of accidental starting when not in use.

VARIABLE SPEED

This tool has a variable speed switch that delivers higher speed with increased trigger pressure. Speed is controlled by the amount of switch trigger depression.

TWO SPEED GEAR TRAIN

Your drill has a two-speed gear train designed for drilling or driving at **LO (1)** or **HI (2)** speeds. A slide switch is located on top of your drill to select either **LO (1)** or **HI (2)** speed.

FORWARD/REVERSE SELECTOR

(DIRECTION OF ROTATION SELECTOR)

The drill-driver has a forward/reverse selector located above the switch trigger.

BIT STORAGE

When not in use, bits provided with your drill-driver can be placed in the storage area located on the top of the motor housing.

LEVEL

To keep drill bit level during drilling operations, a level is located on the top and end of the motor housing.

FEATURES

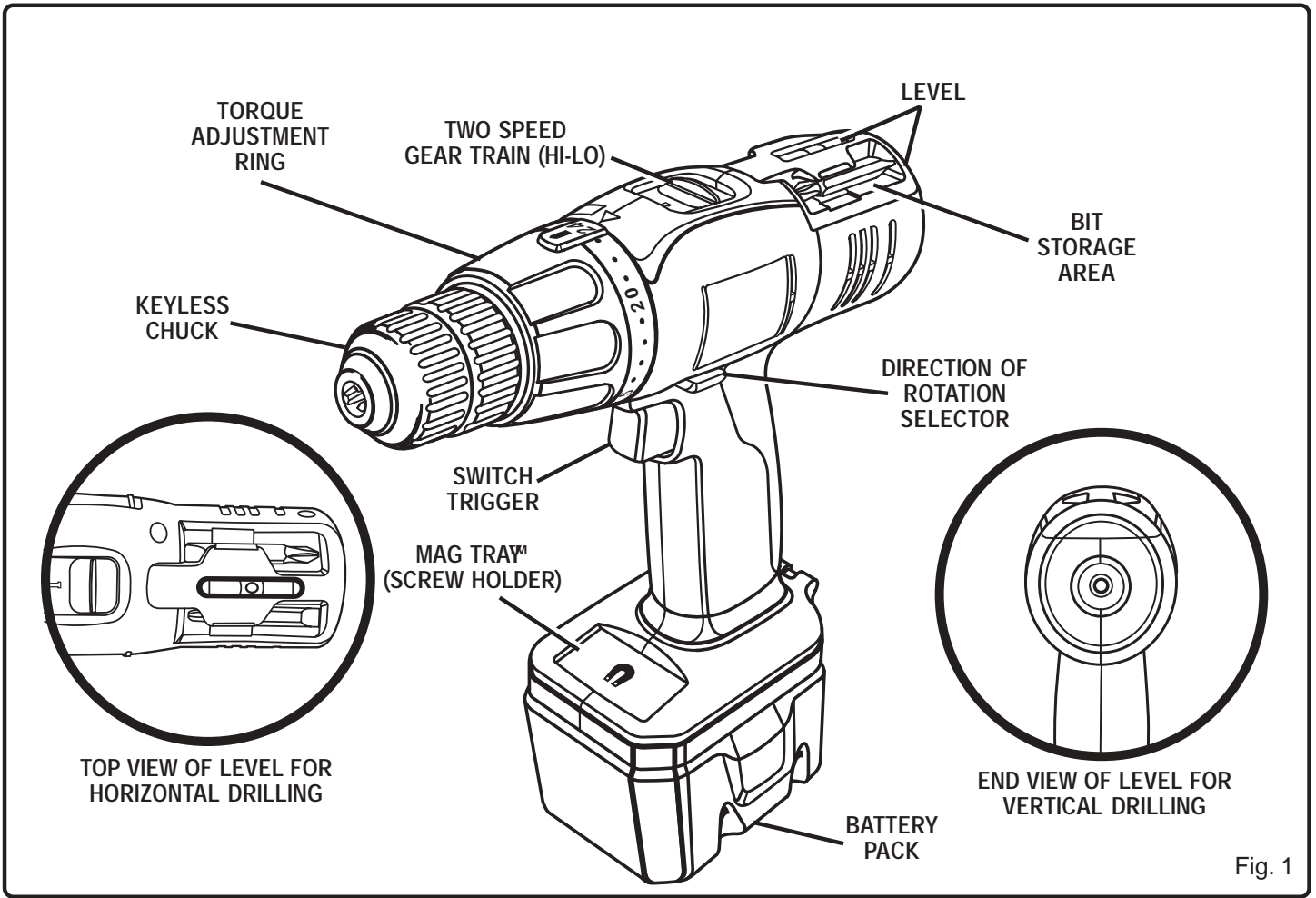

Fig. 1

ADJUSTMENTS

REVERSIBLE

See Figure 2.

This tool is reversible. The direction of rotation is controlled by a selector located above the switch trigger. With the drill held in normal operating position, the direction of rotation selector should be positioned to the left of the switch for drilling. The drilling direction is reversed when the selector is to the right of the switch. When the selector is in center position, the switch trigger is locked.

⚠ CAUTION:

To prevent gear damage, always allow chuck to come to a complete stop before changing the direction of rotation.

To stop, release switch trigger and allow the chuck to come to a complete stop.

⚠ WARNING:

Battery tools are always in operating condition. Therefore, switch should always be locked when not in use or when carrying at your side.

TWO SPEED GEAR TRAIN

See Figure 3.

Your drill has a two-speed gear train designed for drilling or driving at **LO (1)** or **HI (2)** speeds. A slide switch is located on top of your drill to select either **LO (1)** or **HI (2)** speed. When using drill in the **LO (1)** speed range, speed will decrease and unit will have more power and torque. When using drill in the **HI (2)** speed range, speed will increase and unit will have less power and torque. Use **LO (1)** speed for high power and torque applications and **HI (2)** speed for fast drilling or driving applications.

KEYLESS CHUCK

See Figure 3.

A keyless chuck has been provided with your drill to allow for easy installation and removal of bits. As the name implies, you can hand tighten or release drill bits in the chuck jaws. Grasp and hold the collar of the chuck with one hand. Rotate the chuck body with your other hand. The arrows on the chuck indicate which direction to rotate the chuck body in order to **GRIP** (tighten) or **RELEASE** (unlock) the drill bit.

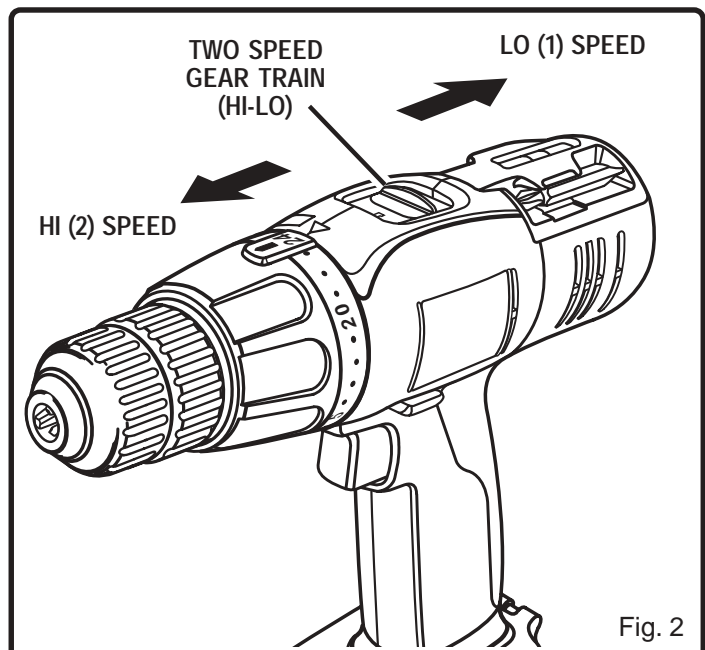

Fig. 2

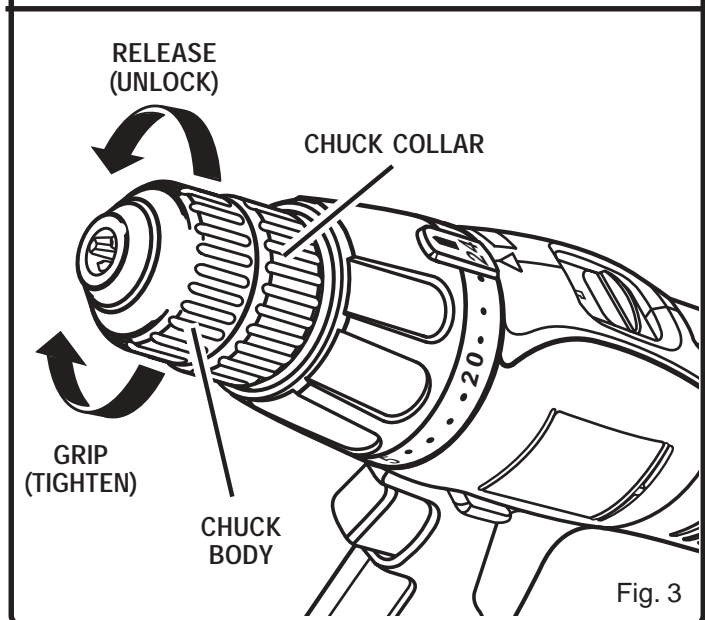

Fig. 3

⚠ WARNING:

Do not hold the chuck body with one hand and use the power of the drill to tighten chuck jaws on drill bits. Chuck body could slip in your hand or your hand could slip and come in contact with rotating drill bit. This could cause an accident resulting in serious personal injury.

ADJUSTMENTS

INSTALLING BITS

See Figures 4 and 5.

- Place the direction of rotation selector in center position. This will lock the switch trigger in the off position. See Figure 10.
- Open or close the chuck jaws to a point where the opening is slightly larger than the bit size you intend to use. Also, raise the front of your drill slightly to keep the bit from falling out of the chuck jaws.
- Insert your drill bit into the chuck the full length of the jaws. See Figure 4.
- Tighten the chuck jaws on the drill bit. To tighten, grasp and hold the collar of the chuck with one hand, while rotating the chuck body with your other hand.
Note: Rotate the chuck body in the direction of the arrow marked **GRIP** to tighten the chuck jaws.
- **DO NOT** use a wrench to tighten or loosen the chuck jaws.

⚠ WARNING:

Do not insert drill bit into chuck jaws and tighten as shown in figure 5. This could cause drill bit to be thrown from drill resulting in possible serious personal injury or damage to the chuck.

REMOVING BITS

See Figure 4.

- Lock the switch trigger by placing the direction of rotation selector in center position. See Figure 10.
- Loosen the chuck jaws from the drill bit.
- To loosen: grasp and hold the collar of the chuck with one hand, while rotating chuck body with your other hand.
NOTE: Rotate chuck body in the direction of the arrow marked **UNLOCK** to loosen chuck jaws.
- **Do not** use a wrench to tighten or loosen the chuck jaws.
- Remove the drill bit from the chuck jaws.

NOTE: Rotate the chuck body in the direction of the arrow marked **GRIP** to tighten the chuck jaws. **DO NOT** use a wrench to tighten or loosen the chuck jaws.

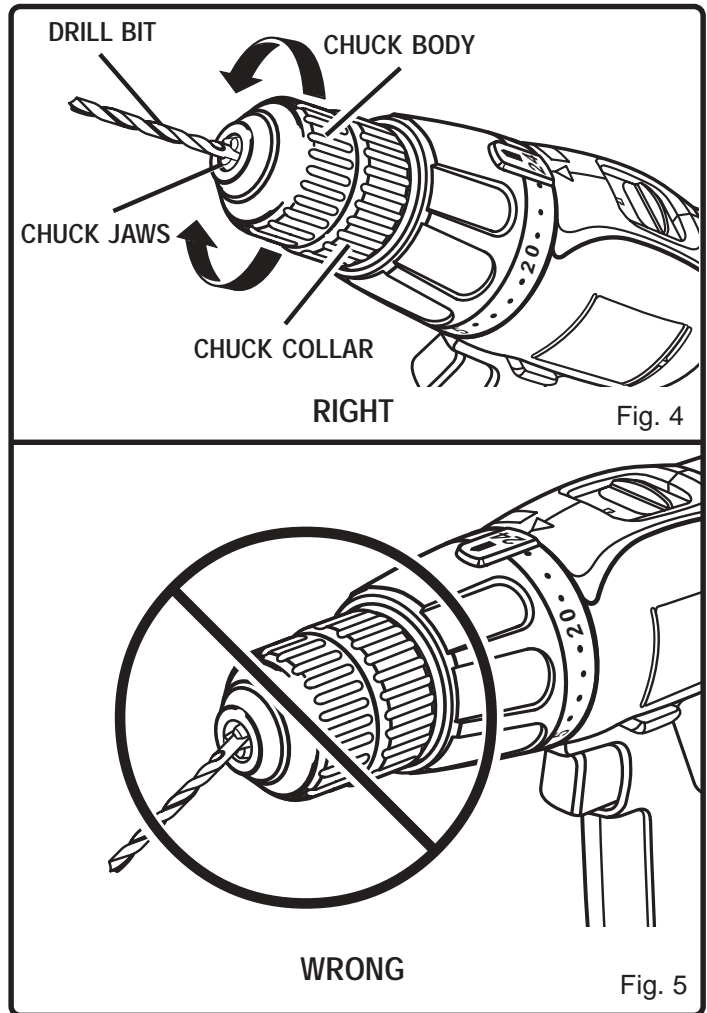

ADJUSTMENTS

ADJUSTABLE TORQUE CLUTCH

See Figure 6.

When using your drill-driver for various driving applications, it becomes necessary to increase or decrease the torque in order to help prevent the possibility of damaging screw heads, threads, workpiece, etc. In general, torque should correspond to the intensity of the screw diameter. If the torque is too high or the screws too small, the screws may be damaged or broken.

The torque is adjusted by rotating the torque adjustment ring. The torque is greater when the torque adjustment ring is set on a higher setting. The torque is less when the torque adjustment ring is set on a lower setting.

The proper setting depends on the type of material and the size of screw you are using.

TO ADJUST TORQUE

- Identify the twenty four torque indicator settings located on the front of the drill.
- Rotate adjusting ring to the desired setting.
 - 1 - 4 For driving small screws.
 - 5 - 8 For driving screws into soft material.
 - 9 - 12 For driving screws into soft and hard materials.
 - 13 - 16 For driving screws in hard wood.
 - 17 - 20 For driving large screws.
 - 21 - 24 (⚡) For heavy drilling.

BIT STORAGE

See Figure 7.

When not in use, bits provided with your drill can be placed in the storage area located on the top of your drill.

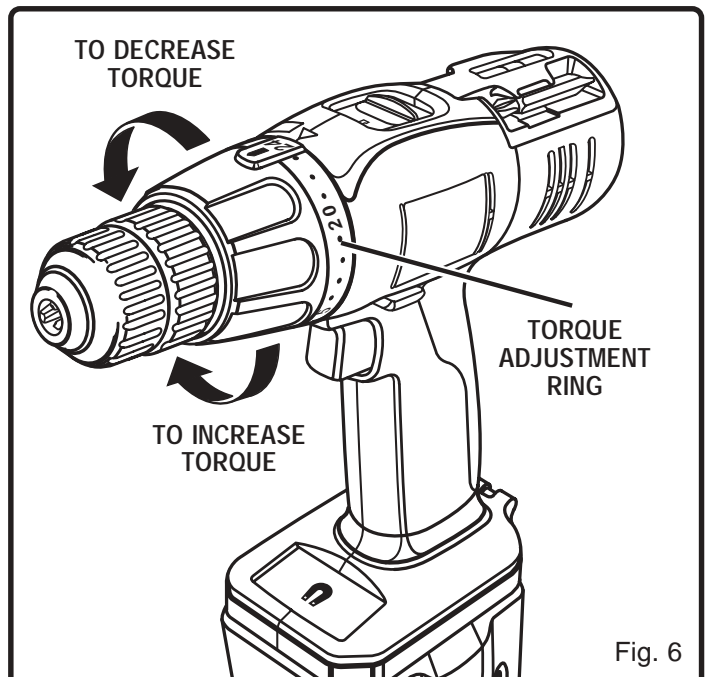

Fig. 6

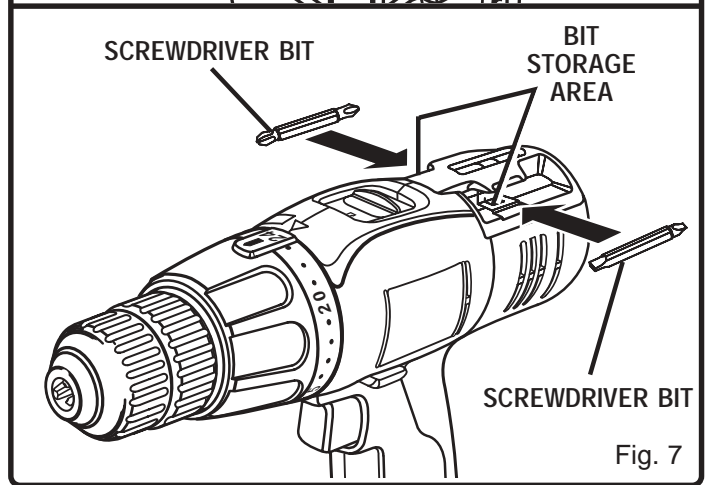

Fig. 7

OPERATION

⚠ WARNING:

Do not allow familiarity with the drill-driver to make you careless. Remember that a careless fraction of a second can result in a serious personal injury.

LED FUNCTION OF CHARGER

See Figure 8.

LED WILL BE LIGHTED TO INDICATE STATUS OF CHARGER AND BATTERY PACK:

- Red LED lighted = Fast Charging Mode
- Green LED lighted = Fully Charged Battery Pack
- Yellow and Green LED Lighted = Control Charge or Defective Battery Pack.

CHARGING YOUR DRILL-DRIVER

The battery pack for this tool has been shipped in a low charge condition to prevent possible problems. Therefore, you should charge it prior to use.

Note: Batteries will not reach full charge the first time they are charged. Allow several cycles (drilling followed by recharging) for them to fully charge.

TO CHARGE

- Charge battery pack only with the charger provided.
- **Make sure power supply is normal house voltage, 120 Volts, 60 Hz, AC only.**
- Connect charger to power supply.
- Place battery pack in charger. See Figure 9. Align raised rib on battery pack with groove in charger.
- Press down on battery pack to be sure contacts on battery pack engage properly with contacts in charger. When properly connected, red light will turn on.
- Normally, the yellow and green lights on the charger will come on. This indicates charger is in control charge mode and should switch to fast charge mode within 5 minutes. When charger is in fast charge mode the red light will come on. If after a period of 15 minutes the yellow and green lights remain on, remove the battery pack, wait 1 minute and reinsert battery pack in charger. If the yellow and green lights continue to remain on an additional 15 minutes, the battery pack is damaged and will not accept charge.
- When your battery pack becomes fully charged, the red light will turn off and the green light will turn on.
- After normal usage, 1 hour of charge time is required to be fully charged. A minimum charge time of 1 to 1-1/2 hours is required to recharge a completely discharged tool.
- The battery pack will become slightly warm to the touch while charging. This is normal and does not indicate a problem.
- **DO NOT** place charger in an area of extreme heat or cold. It will work best at normal room temperature.

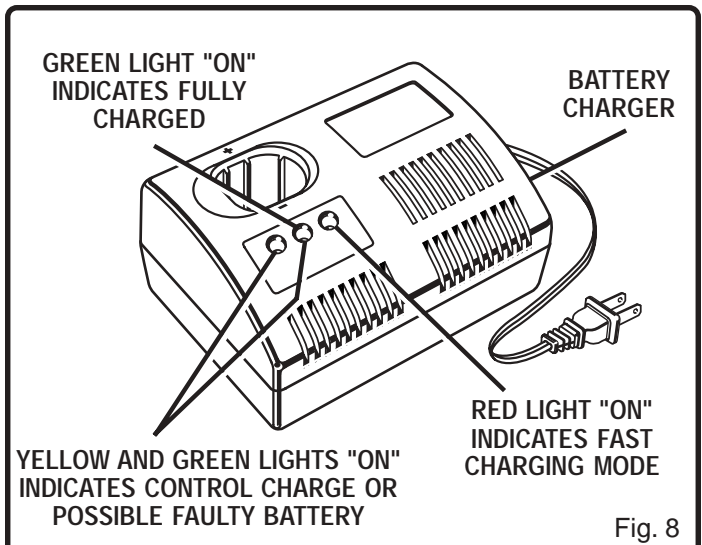

Fig. 8

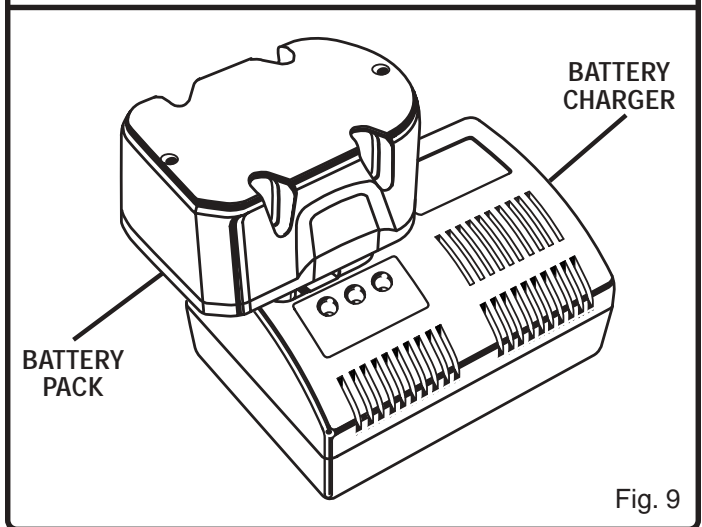

Fig. 9

OPERATION

IMPORTANT INFORMATION FOR RECHARGING HOT BATTERIES

When using your drill-driver continuously, the batteries in your battery pack become hot. You should let a hot battery pack cool down for approximately 30 minutes before attempting to recharge.

Note: This situation occurs when continuous use of your drill-driver causes the batteries to become hot. It does not occur under normal circumstances. Refer to "Charging Your Drill-Driver" earlier in this manual, for normal recharging of batteries. If the charger/charging assembly does not charge your battery pack under normal circumstances, return **both** the battery pack and charger/charging assembly to your nearest **Ryobi Authorized Service Center** for electrical check.

For more information on the battery recycling call **1-800-8 BATTERY**.

TO INSTALL BATTERY PACK

- Place the direction of rotation selector in center position. *See Figure 10.*
- Place the battery pack in your drill. Align raised rib on battery pack with groove in drill's battery port. *See Figure 11.*
- Make sure the latches on each side of your battery pack snap in place and that battery pack is secured in drill before beginning operation.

TO REMOVE BATTERY PACK

- Place the direction of rotation selector in center position. *See Figure 10.*
- Locate latches on side of battery pack and depress both sides to release battery pack from your drill. *See Figure 11.*
- Remove battery pack from your drill.

CAUTION:

When placing battery pack in your drill, be sure raised rib on battery pack aligns with groove in drill's battery port and latches snap in place properly. Improper assembly of battery pack can cause damage to internal components.

SWITCH

See Figure 10.

To turn your drill **ON**, depress the switch trigger. To turn it **OFF**, release the switch trigger.

SWITCH LOCK

See Figure 10.

The switch trigger can be locked in the **OFF** position. This feature helps reduce the possibility of accidental starting when not in use. To lock the switch trigger, place the direction of rotation selector in the center position.

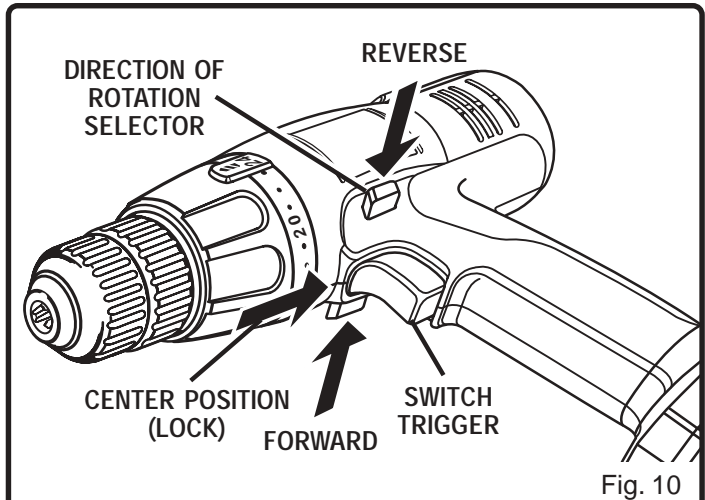

Fig. 10

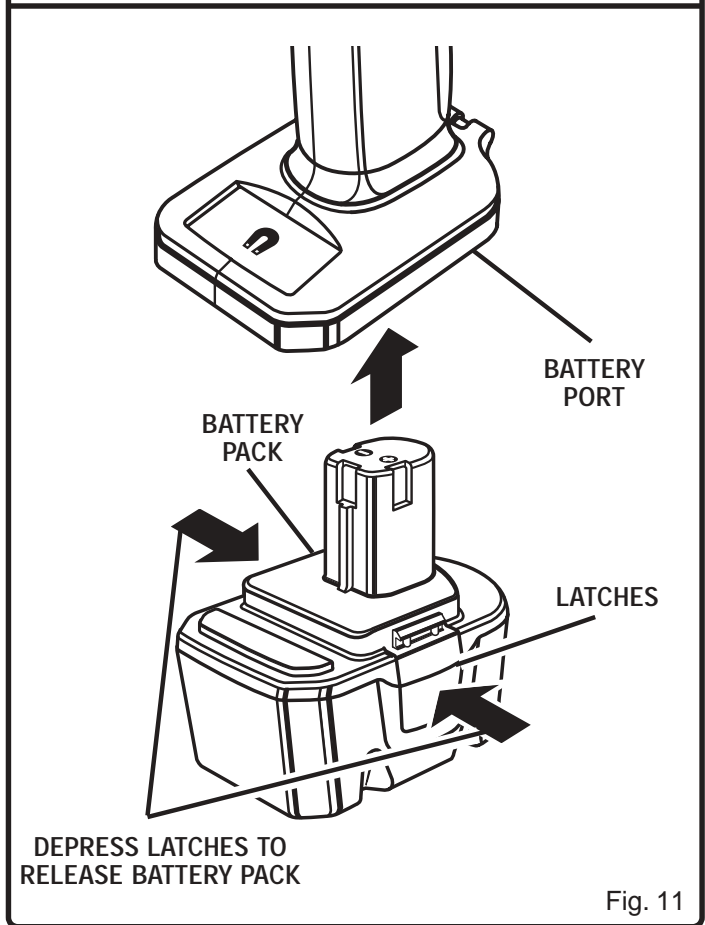

Fig. 11

VARIABLE SPEED

See Figure 10.

Your drill has a variable speed feature in the switch. The switch delivers higher speed and torque with increased trigger pressure. Speed is controlled by the amount of switch trigger depression.

OPERATION

⚠ WARNING:

Always wear safety goggles or safety glasses with side shields when operating tool. Failure to do so could result in objects being thrown into your eyes, resulting in possible serious injury.

DRILLING

See Figure 12.

When drilling hard, smooth surfaces, use a center punch to mark the desired hole location. This will prevent the drill bit from slipping off center as the hole is started. However, the lower speed feature allows starting holes without center punching if desired. To accomplish this, simply operate your drill at lower speed until the hole is started.

The material to be drilled should be secured in a vise or with clamps to keep it from turning as the drill bit rotates.

Hold tool firmly and place the bit at the point to be drilled. Depress the switch trigger to start tool.

Move the drill bit into the workpiece, applying only enough pressure to keep the bit cutting. Do not force or apply side pressure to elongate a hole.

⚠ WARNING:

Be prepared for binding or bit breakthrough. When these situations occur, the drill has a tendency to grab and kick opposite to the direction of rotation, and could cause loss of control when breaking through material. If you are not prepared, this loss of control can result in possible serious injury.

When drilling metals, use a light oil on the drill bit to keep it from overheating. The oil will prolong the life of the bit and increase the drilling action.

If the bit jams in workpiece or if the drill stalls, release switch trigger immediately. Remove the bit from the workpiece and determine the reason for jamming.

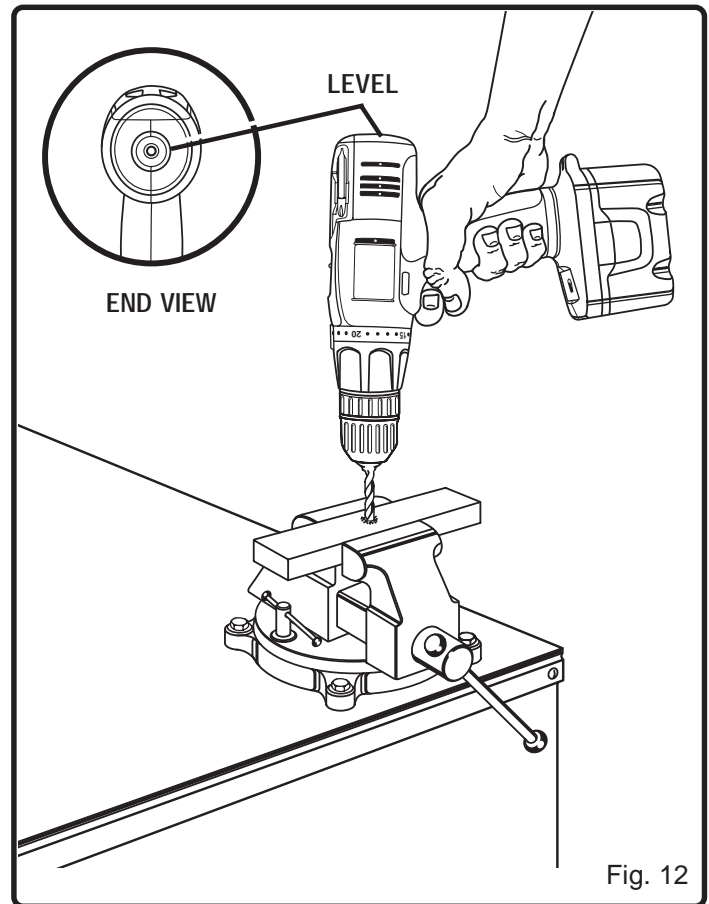

OPERATION

LEVEL DRILLING

See Figures 12 and 13.

A convenient new feature provided with your drill is a level. It is recessed in the motor housing on top of your drill. It can be used to keep drill bit level during drilling operations.

⚠ WARNING:

Do not force tool. Forcing tool can result in jamming and loss of balance or footing, which could result in personal injury.

MAG TRAY™

See Figure 14.

For convenience, your drill has a Mag Tray™ to place small parts when doing a variety of tasks.

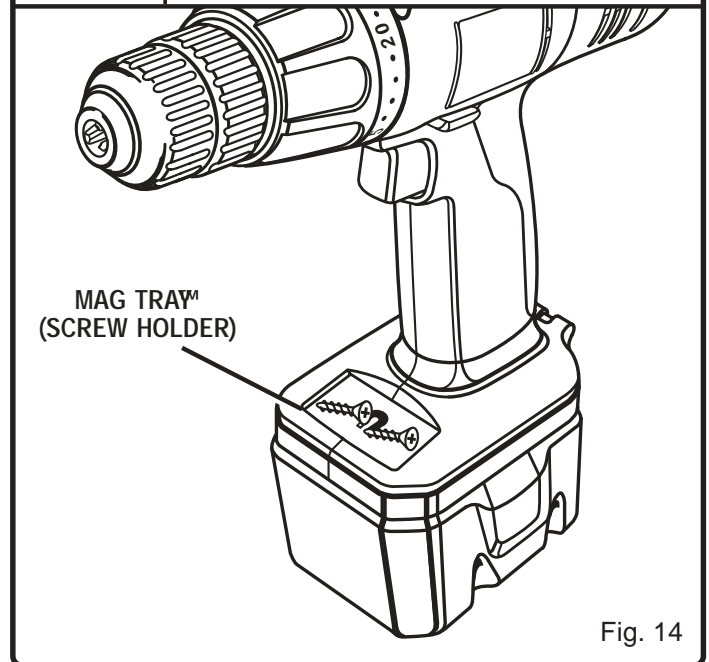
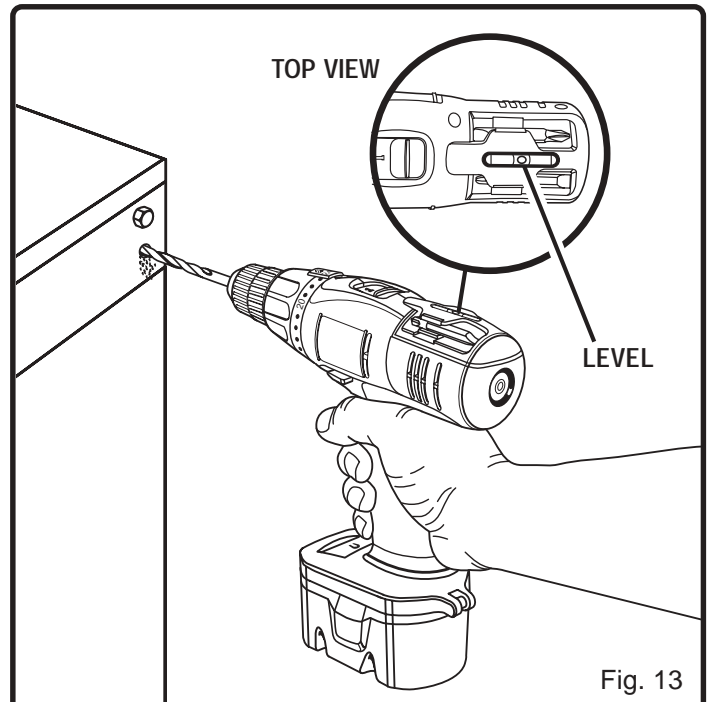

MAINTENANCE

⚠ WARNING:

When servicing use only identical Ryobi replacement parts. Use of any other parts may create a hazard or cause product damage.

Do not abuse power tools. Abusive practices can damage tool as well as workpiece.

⚠ WARNING:

Do not at any time let brake fluids, gasoline, petroleum-based products, penetrating oils, etc. come in contact with plastic parts. They contain chemicals that can damage, weaken or destroy plastic.

⚠ WARNING:

Do not attempt to modify this tool or create accessories not recommended for use with this tool. Any such alteration or modification is misuse and could result in a hazardous condition leading to possible serious personal injury.

GENERAL

Avoid using solvents when cleaning plastic parts. Most plastics are susceptible to damage from various types of commercial solvents and may be damaged by their use. Use clean cloths to remove dirt, carbon dust, etc. that can damage, weaken, or destroy plastic.

⚠ WARNING:

Always wear eye protection marked to comply with ANSI Z87.1. Failure to do so could result in dust, shavings, or loose particles being thrown into your eyes, resulting in possible serious injury.

CHUCK REMOVAL

See Figures 15, 16, and 17.

- The chuck must be removed in order to use some accessories. To remove:
- Lock the switch trigger by placing the direction of rotation selector in center position. See Figure 4.
- Insert a 5/16 in. or larger hex key into the chuck of the drill and tighten the chuck jaws securely.
- Tap the hex key sharply with a mallet in a clockwise direction. See Figure 15. This will loosen the screw in the chuck for easy removal.

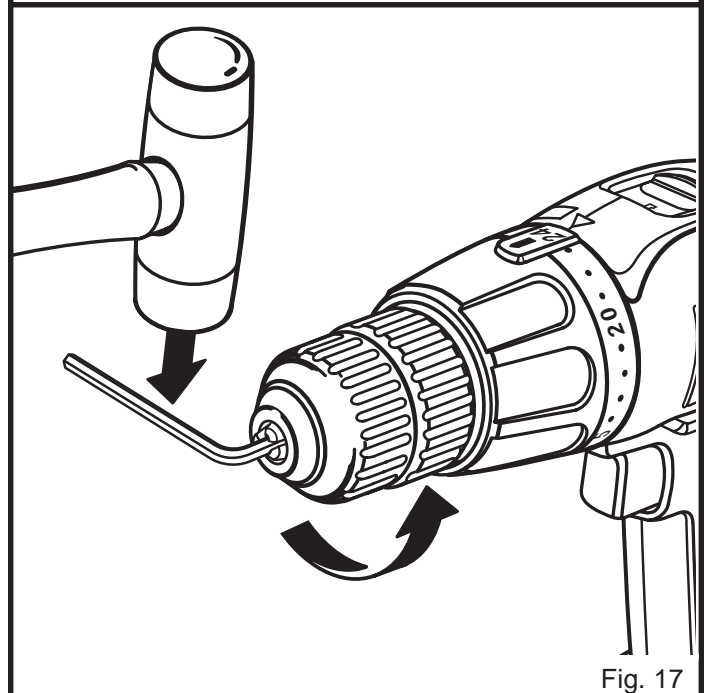
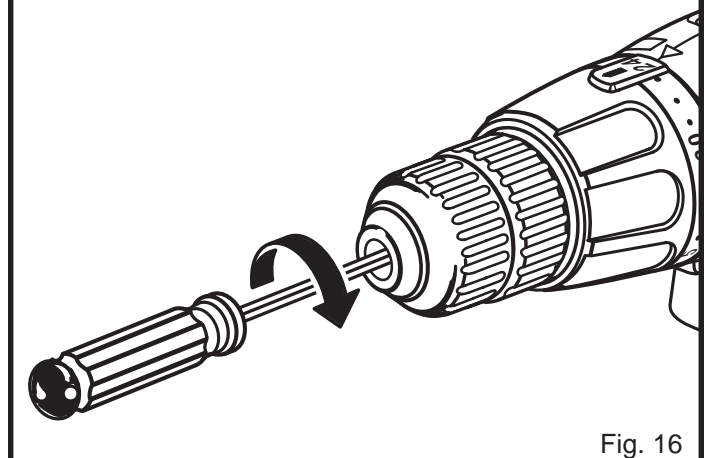
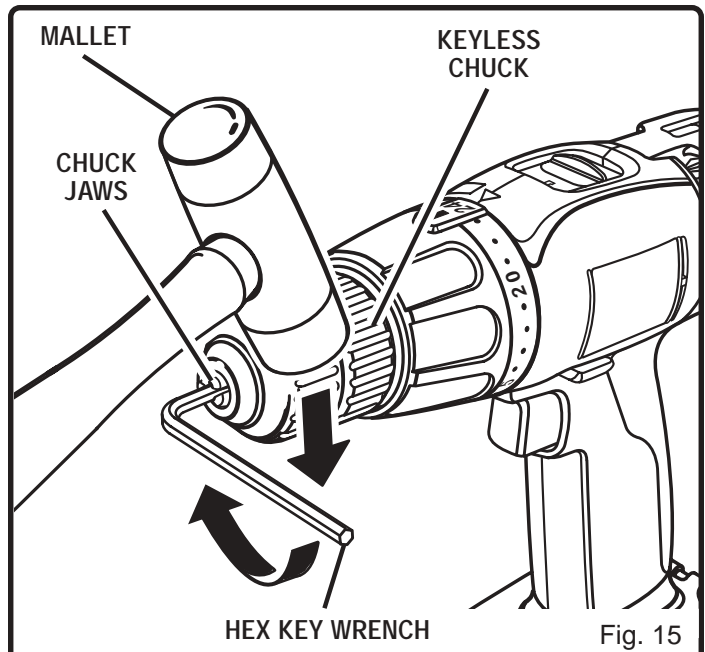

MAINTENANCE

- Open the chuck jaws and remove the hex key. Remove the chuck screw by turning it in a clockwise direction. *See Figure 16.*

NOTE: The screw has left hand threads.

- Insert the hex key in the chuck and tighten chuck jaws securely. Tap sharply with a mallet in a counterclockwise direction. This will loosen the chuck on the spindle. It can now be unscrewed by hand. *See Figure 17.*

TO RETIGHTEN A LOOSE CHUCK

See Figure 17.

The chuck may become loose on spindle and develop a wobble. Periodically check chuck screw for tightness.

To tighten, follow these steps:

- Lock the switch trigger by placing the direction of rotation selector in center position. *See Figure 4.*
- Open the chuck jaws.
- Insert the hex key into the chuck and tighten chuck jaws securely. Tap the hex key sharply with a mallet in a clockwise direction. This will tighten the chuck on the spindle. *See Figure 17.*
- Open the chuck jaws and remove the hex key.
- Tighten the chuck screw.

NOTE: The chuck screw has left hand threads.

BATTERIES

The battery pack for your tool is equipped with nickel-cadmium rechargeable batteries. Length of service from each charging will depend on the type of work you are doing.

The batteries in this tool have been designed to provide maximum trouble free life. However, like all batteries, they will eventually wear out. **Do not** disassemble battery pack and attempt to replace the batteries. Handling of these batteries, especially when wearing rings and jewelry, could result in a serious burn.

To obtain the longest possible battery life, we suggest the following:

- Store and charge your batteries in a cool area. Temperatures below 50°F or above 100°F will shorten battery life.
- Never store batteries in a discharged condition. Recharge them immediately after they are discharged.
- All batteries gradually lose their charge. The higher the temperature the quicker they lose their charge. If you store your tool for long periods of time without using it, recharge the batteries every month or two. This practice will prolong battery life.

BATTERY PACK REMOVAL AND PREPARATION FOR RECYCLING

WARNING:

Upon removal, cover the battery pack's terminals with heavy duty adhesive tape. Do not attempt to destroy or disassemble battery pack or remove any of its components. Nickel-cadmium batteries must be recycled or disposed of properly. Also, never touch both terminals with metal objects and/or body parts as short circuit may result. Keep away from children. Failure to comply with these warnings could result in fire and/or serious injury.



To preserve natural resources, please recycle or dispose of batteries properly.

This product contains nickel-cadmium batteries. Local, state or federal laws may prohibit disposal of nickel-cadmium batteries in ordinary trash.

Consult your local waste authority for information regarding available recycling and/or disposal options

NOTES



OPERATOR'S MANUAL

CORDLESS DRILL-DRIVER

MODEL NOS. SA1202 / SA14402 / SA1802

- **SERVICE**

Now that you have purchased your tool, should a need ever exist for repair parts or service, simply contact your nearest Ryobi Authorized Service Center. Be sure to provide all pertinent facts when you call or visit. Please call 1-800-525-2579 for your nearest Ryobi Authorized Service Center. You can also check our web site at www.ryobitools.com for a complete list of Authorized Service Centers.

- **MODEL NO. AND SERIAL NO.**

The model number of this tool will be found on a plate attached to the motor housing. Please record the model number and serial number in the space provided below.

- **HOW TO ORDER REPAIR PARTS**

WHEN ORDERING REPAIR PARTS,
ALWAYS GIVE THE FOLLOWING INFORMATION:

- MODEL NUMBERS SA1202 / SA14402 / SA1802
- SERIAL NUMBER _____

Ryobi® is a registered trademark of Ryobi Limited used under license.

ONE WORLD TECHNOLOGIES, INC.
1428 Pearman Dairy Road, Anderson SC 29625
Phone 1-800-525-2579
www.ryobitools.com